

TYPE SS-INOX

Stainless Steel Centrifugal Pumps

DIN 24255

Applications

- For clean or turbid liquids, free from large solids
- For pumping water, petrol, benzene, oil, brine, alkaline solution and mild acids
- For circulation, irrigation and drainage purposes
- For water supply and booster stations
- For industrial and Agricultural applications and in Public services
- For pharmaceutical beverage food and refining chemical

Performance Limits

- Capacity up to 85 m³/hr
- Total head up to 85m
- Max. working pressure : 10 bar
- Max. liquid temperature : 110°C

Materials

- Pump casing, impellers and shaft : AISI 304 or 316 L stainless steel
- Mechanical seal :
NBR / ceramic / carbon : 80°C
Viton / ceramic / carbon : -20°C ~+110°C

Motors

- TEFC, IP55 protection
- Insulation class F
- 50Hz or 60Hz
- 2 poles or 4 poles

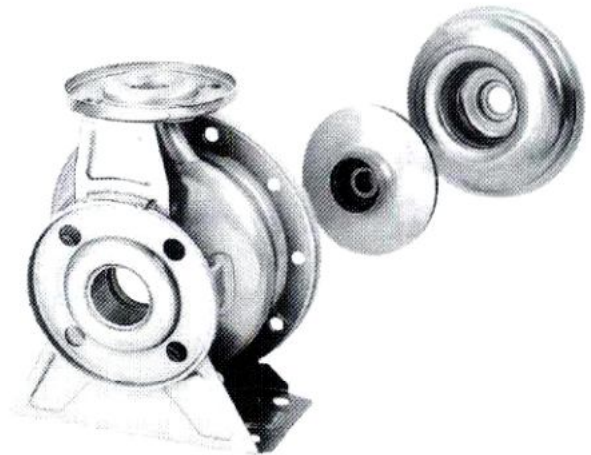

Design Features

- Single stage centrifugal pump in compact design.
- Back pull-out design allows easy access to rotating elements for routine maintenance without disturbing pipework.
- Simple installation.
- No alignment problems
- All pumps fitted with self adjusting mechanical seal of design proven to eliminate gland leakage.
- Possibility of horizontal and vertical installation.



DRAKOS - POLEMIS INC
PUMP MANUFACTURERS

PLANT & HEAD OFFICE

Kryoneri - Attiki

Tel.: ++ 30(1) 81 61 402 Fax: ++ 30(1) 81 61 262

Post Address: P.O. Box 51024 GR-145 Kifissia, Athens Greece.

Performance Data : 2 Pole 50 Hz

Curves at 2900 r.p.m. Test water temperature : 20°C. Performance limits : ISO 2548 for Production of Class C Pumps

Model DIN 24255	Power		Q. Capacity												H. Head (m)											
	Kw	HP	L/min	50	100	150	200	250	300	333	400	450	500	550	600	650	700	800	1000	1200						
			m ³ /h	3.0	6.0	9.0	12	15	18	20	24	27	30	33	36	39	42	48	60	72						
SS-32-125/1.5	1.5	2.0	22	21.6	21.4	20.5	18.6	16.2																		
SS-32-160/2.2	2.2	3.0	35	34	33.5	33	32.5	32.1																		
SS-32-160/1.5	1.5	3.2	26.5	26.1	25.5	25	24.6	24																		
SS-32-200/3.0	3.0	4.0	41.4	40.5	39.7	39	38.5	37																		
SS-32-200/4.0	4.0	5.5	52	50.7	49.6	48.8	48.2	46.8																		
SS-32-200/5.5	5.5	7.5	57.7	57.5	56.2	55.9	55.3	55																		
SS-40-125/1.5	1.5	2.0				16	15.5	15	14.5	13.8	12.9	11.7	11													
SS-40-125/2.2	2.2	3.0				21.8	21.5	21.3	21.1	20.7	20.2	19.5	18.4	17.3												
SS-40-160/3.0	3.0	4.0				28.5	28	27.4	27.1	26.3	25.4	24.3	22.9	21.7												
SS-40-160/4.0	4.0	5.5				36.2	36	35.6	35	33.8	33.4	32.4	31.3	29.5												
SS-40-200/5.5	5.5	7.5				45.2	44.8	44.1	43.4	42.7	42.1	41.3	40.1	38.7												
SS-40-200/7.5	7.5	10				54.8	54.8	54	53	52	51.2	49.6	49	48.2												
SS-40-200/9.2	9.2	12.5				58.8	58.4	58	57.5	56.7	56	55.4	54.8	54												
SS-50-125/3.0	3.0	4.0								21.6	21.2	20.5	20	19.2	18.2	17.5	15.5	12.5								
SS-50-125/4.0	4.0	5.5								25.6	25.4	24.9	24.5	23.8	23.3	22.6	21.1	19								
SS-50-160/5.5	5.5	7.5								29.8	29.5	28.9	28.7	27.9	27.9	27.4	25.9	23								
SS-50-160/7.5	7.5	10								35.1	34.9	34.6	34.2	33.2	33.3	32.6	31.4	28.5								
SS-50-200/9.2	9.2	12.5								49.2	48.8	48.6	48.3	47.7	47.5	47	46.1	41								
SS-50-200/11.0	11	15								53.3	52.8	52.3	52	51.8	51.6	51.2	49.6	46.8								
SS-50-200/15.0	15	20								58.3	57.8	57.5	57.3	57.1	57	56.8	56.6	51.3								

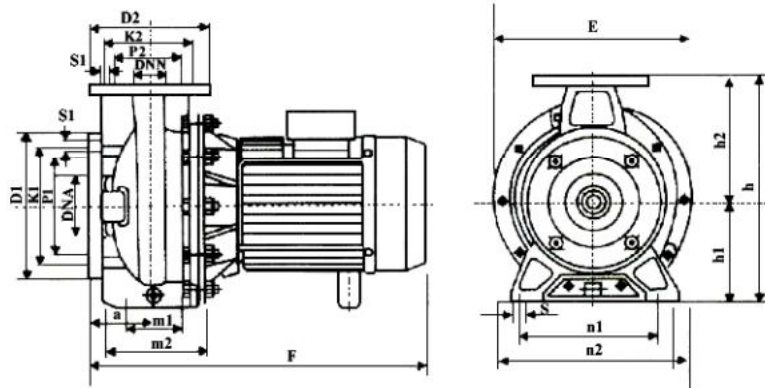

Type SS-INOX

Model	E	F	h	h1	h2	a	m1	m2	n1	n2	S	D1	K1	P1	S1	D2	K2	P2	S1	DNA	DNM	Weight (kg)
SS-32-125/1.5	244	415	292	132	160	80	70	118	190	240	15	165	125	99	18	140	100	76	18	50	32	26
SS-32-160/1.5	244	415	292	132	160	80	70	118	190	240	15	165	125	99	18	140	100	76	18	50	32	26
SS-32-160/2.2	244	440	292	132	160	80	70	118	190	240	15	165	125	99	18	140	100	76	18	50	32	29
SS-32-200/3	295	475	340	160	180	80	70	118	190	240	15	165	125	99	18	140	100	76	18	50	32	40
SS-32-200/4	295	475	340	160	180	80	70	118	190	240	15	165	125	99	18	140	100	76	18	50	32	43
SS-40-200/5.5	295	560	340	160	180	100	70	136	212	265	15	185	145	118	18	150	110	84	18	65	40	63
SS-40-200/7.5	295	560	340	160	180	100	70	136	212	265	15	185	145	118	18	150	110	84	18	65	40	67
SS-40-125/3.0	244	415	292	132	160	80	70	118	190	240	15	185	145	118	18	165	125	99	18	65	40	26.5
SS-40-125/4.0	244	440	292	132	160	80	70	118	190	240	15	185	145	118	18	165	125	99	18	65	40	29.35
SS-40-160/5.5	244	475	292	132	160	80	70	118	190	240	15	185	145	118	18	165	125	99	18	65	40	35.5
SS-40-160/7.5	244	475	292	132	160	80	70	118	190	240	15	185	145	118	18	165	125	99	18	65	40	39.5
SS-40-200/9.2	295	605	360	160	200	100	70	140	212	265	15	200	160	132	18	165	125	99	18	65	40	70
SS-40-200/11.0	295	625	360	160	200	100	70	140	212	265	15	200	160	132	18	165	125	99	18	65	40	85
SS-50-125/3.0	244	500	340	160	180	100	70	142	212	265	15	200	160	132	18	185	145	118	18	65	50	35.5
SS-50-125/4.0	244	500	340	160	180	100	70	142	212	265	15	200	160	132	18	185	145	118	18	65	50	41
SS-50-160/5.5	244	570	340	160	180	100	70	142	212	265	15	200	160	132	18	185	145	118	18	65	50	60.5
SS-50-160/7.5	244	570	340	160	180	100	70	142	212	265	15	200	160	132	18	185	145	118	18	65	50	64



DRAKOS - POLEMIS INC
PUMP MANUFACTURERS