

## Type IL Vertical In Line Pump Model: ISG(B)



### Feature

- Wide performance range
- High efficiency and power saving
- Super noiseless low vibration
- Convenient installation and inspection

### Performance Range

- Capacity: 4 m<sup>3</sup>/hr to 1080 m<sup>3</sup>/hr
- Head: 8m to 125m
- Suction Pressure: 1.6 Mpa

### Application

- High water container and fire fighting
- Long distance water supply
- Boiler water feeding
- Air condition water circulating



**DRAKOS - POLEMIS INC**  
PUMP MANUFACTURERS

# Structure Drawing

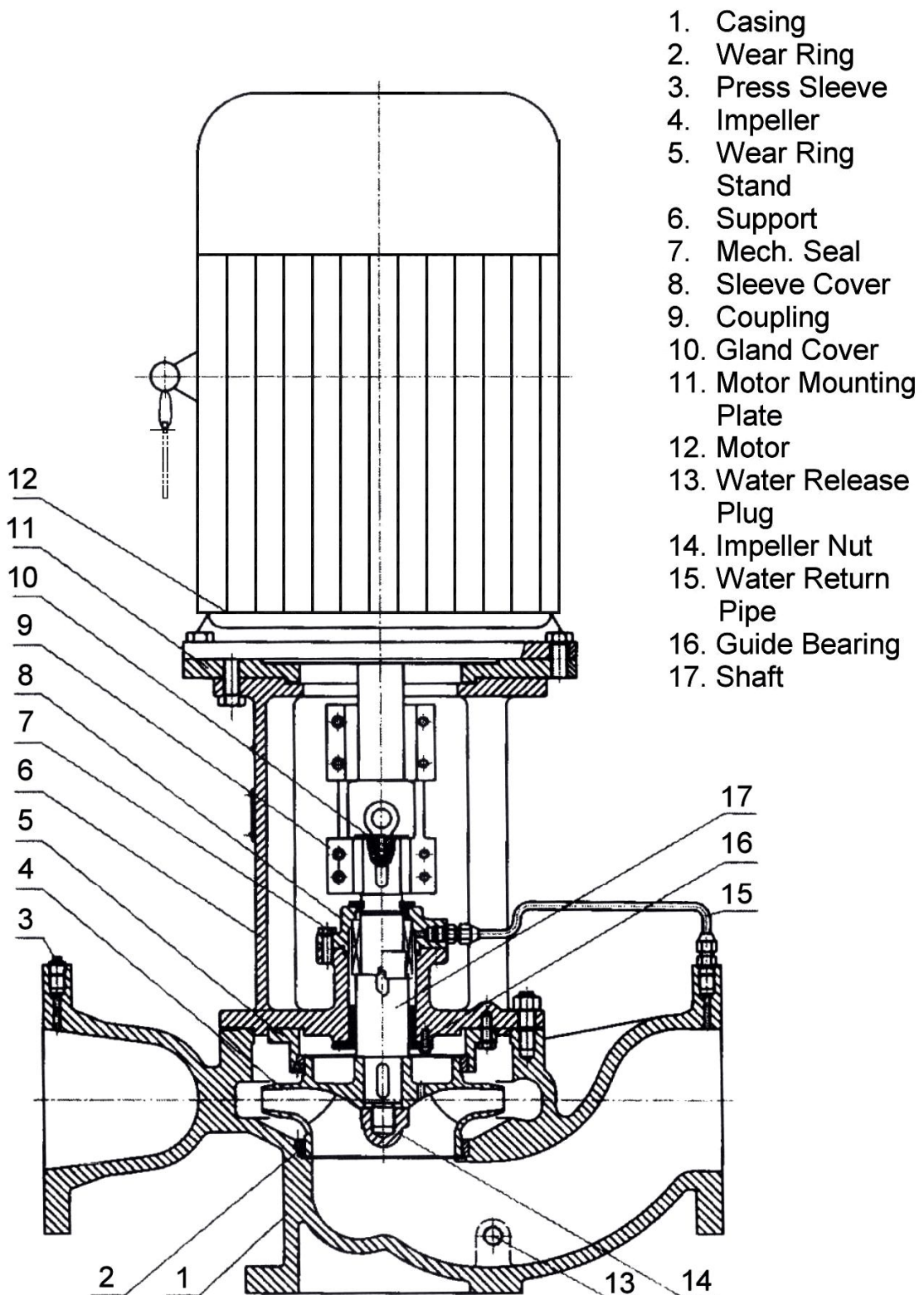

**DRAKOS - POLEMIS INC**  
**PUMP MANUFACTURERS**