

# Type AVST

## Submersible Propeller Pump For Pump Tube Installation

Model QZ (Axial Flow)

Model QH (Mixed Flow)

**Robust Reliable Construction Simple  
and Economical Installation**

### Applications:

- Flood Control
- Drainage / Irrigation / Storm Water Pumping Station
- Raw Water Intake
- Cooling Water Pump in Power Stations and Industry
- Municipal Sewage Treatment Plant

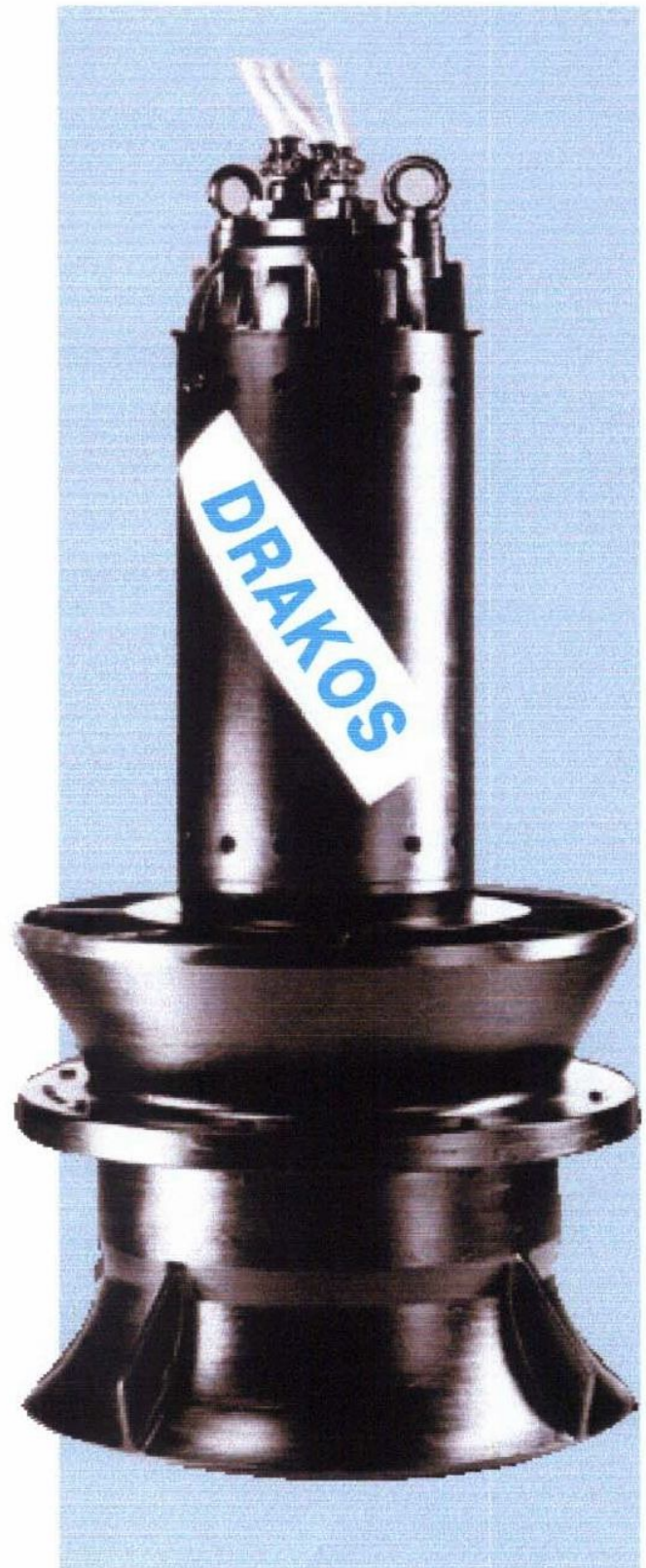
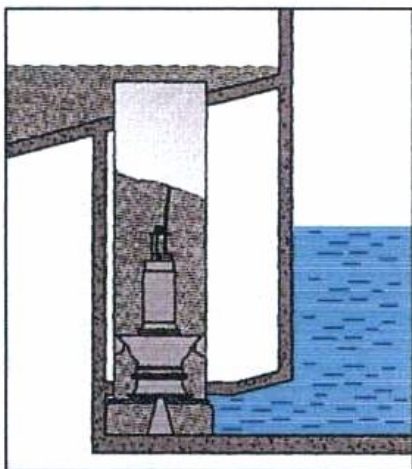
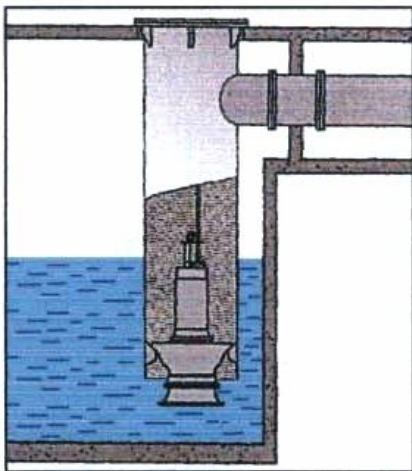

**DRAKOS - POLEMIS S.A.**  
PUMP MANUFACTURERS

Kryoneri - Athens - Greece

## Features:

### Cable Protection

Finger-sleeve type seal prevents the cable surface from getting damaged, the cable tip from falling into the water and the motor's cavity from water and enhances the motor's dielectric grade. The dirt-resisting heavy rubber soft cable uses a rubber ring for sealing, which can tightly press and fix it to let it not loose and run reliably for a long time.

### Seal

Two or three mechanical seals are set, the first one directly contacts with water and is silicon carbide two silicon carbide, the second and third ones are graphite to silicon carbide. Multiply protected, without leak and absolutely safe for bearing and motor.

### Impeller

It uses the most excellent hydraulic modeling at present. Is improved and designed by means of aiming at the submersible structure, leaving a high efficiency with the pump, an adjustable angle for it to be placed and a highly effective running under multiple working condition for one impeller.

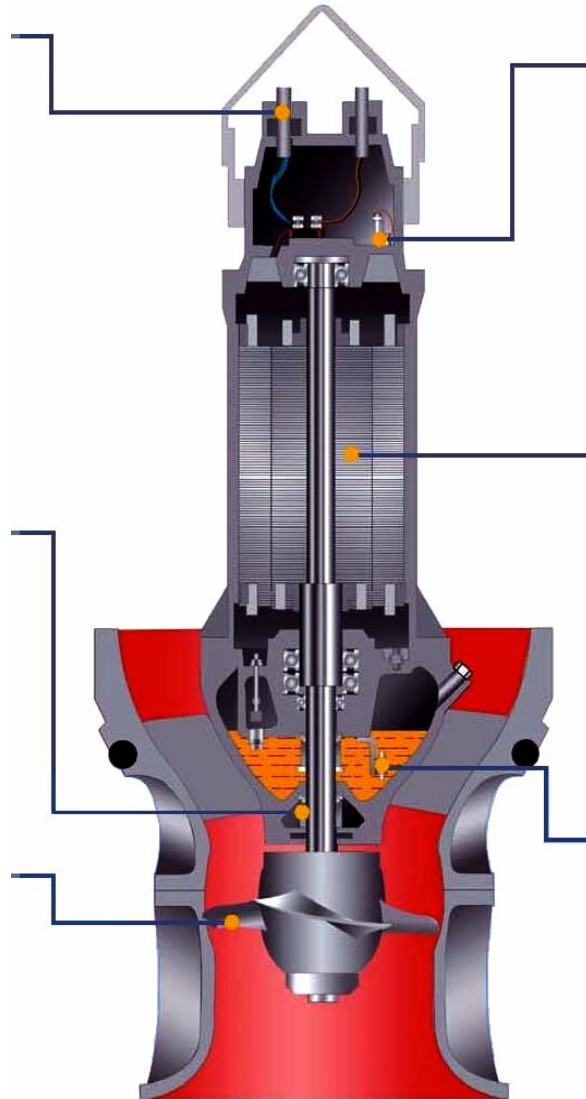

### Water leakage Sensor

When water goes into the motor's cavity and surpass as a certain concentration, the upper water leak sensor will send out a warning signal and stop pump from running.

### Overload Protective Sensor

There is a overheat protector in the winding of the submersible motor and, when the temperature is over the set one, it will send out a signal and stop pump from running.

### Oil-Water Leakage Sensor

When water goes into the oil chamber and is over a certain concentration and height, the lower water leakage sensor will send out a warning signal.

## Specifications:

- Power Rating : up to 1120kw
- Flow Rate : up to 11,000 l/s
- Head : up to 21 m
- Fluid Temperature : up to 50° C
- Max. Submergence : 20 m
- Rotating Direction : The impeller is rotating Clock Wise by viewing from the top
- Max. Working Pressure : 10 Bar

### Motor

- Air Filled, Water Cooling
- Voltage : up to 355kw, 380v – 660V  
: above 355kw, 380V – 660V,  
6kV, 10kV
- Insulation : Class F
- Protection Class : IP68
- Rated Power : 50 Hz
- Length of Cable : 10 m

### Materials of Construction

- Pump Casing : Cast Iron
- Impeller : Stainless Steel
- Shaft : Stainless Steel
- Mechanical Seal : 1st – Silicon Carbide/Silicon Carbide  
: 2nd & 3rd – Graphite/Silicon Carbide

- Nut & Bolts : Stainless Steel
- O Ring : NBR